



Oregon School Activities Association
25200 SW Parkway Avenue, Suite 1
Wilsonville, OR 97070
503.682.6722 fax: 503.682.0960 <http://www.osaa.org>



May 11, 2021

To: Commissioners, Athletic Directors and Head Wrestling Coaches
From: Brad Garrett, Assistant Executive Director
Subject: First Contest Date Reminders

As we approach the first contest I wanted to remind all of you of the policies related to the areas listed below. Please take a few moments to review these items prior your first contest. Questions related to any of the policies below can be directed to me at bradg@osaa.org.

Questions, answers and help video related to the topics below can be found on the TrackWrestling General Team Admin page located at - <http://www.trackwrestling.com/tw/FAQPlan.jsp?planId=139044009> and on the Oregon Wrestling Weight Monitoring Program page at <http://www.osaa.org/activities/wre/information/owwmp>.

Varsity Schedule Deadline:

As outlined in OSAA Executive Board Policy the deadline to enter your Varsity wrestling schedules into your TrackWrestling account is prior to the first contest date (Monday, May 17,2021).

Schools are reminded to only enter those events that you are hosting and verify that you have added the correct teams to the event – this will automatically populate the invited team’s accounts.

If you are missing an away event that should be on your schedule but does not appear then contact the hosting team and request they add you to the event.

Each member school is responsible to verify the schedule is as accurate as possible but does allow schools to enter additional events after the deadline if needed because of required schedule adjustments.

This memo will help if you have additional questions - <https://www.osaa.org/docs/wre/firstdateremind.pdf>

Season 4 Weigh-in Options/OSAA Weigh-in Form:

The growth allowance has been granted – all weight classes are +2

Day of event home site weigh-ins are permitted during Season 4 but not required. Given the variations in county risk levels and district adopted protocols there is no one policy that will cover all potential competition situations. Below are guidelines for consideration if conducting day of event home site weigh-ins:

- League/Conference Events – establish standard time frame for all league events.
- Multi-team/Non-League Events – event host is responsible to establish and communicate a defined weigh-in time frame for all participating teams. Consideration should be given to travel time required to attend the event.

If used, onsite weigh-ins should be conducted by team if possible following NFHS Wrestling Rule 4.

Regardless of the type of weigh-in used, home site or on-site, coaches shall present an OSAA Weigh-in Report for each event at the scale prior to the weigh-in. The weigh-in report is a printed roster containing a listing of their potential

wrestlers and the two eligible weight classes for each wrestler on that competition date. A school administrator is responsible to verify that each wrestler's actual weight and weight class of participation that day are recorded on the weigh-in report and provided to the event host to verify weight class of participation at each event.

A screen capture of how to create and print an OSAA Weigh-in Report for any event can be accessed at the link below:

<https://www.youtube.com/watch?v=C9JfMuDBqJA>

In addition the school's Athletic Director is responsible to verify that the season long weight loss plan for any wrestler who has failed to qualify at one of their eligible weight classes and chooses to participate in the event has been modified by raising the wrestlers minimum weight class up one class for each occurrence during the season. A review of each events required OSAA Weigh-in report will provide the information necessary to determine if a wrestlers season long plan must be revised.

A screen capture of how to raise a wrestler's minimum weight class at any point during the season, whether by choice or requirement, can be accessed at the link below:

<https://www.youtube.com/watch?v=K8xb2Qz4Mhw>

Entering Required Match Data:

Member schools shall verify after all Varsity dual meets and Varsity tournaments (individual and dual meet formats) that complete results for all wrestlers are entered into the school's assigned TrackWrestling team account and have been verified and accepted.

A memo outlining the process that will be used to input female wrestler match data is posted the OWWMP page at the following link - <https://www.osaa.org/docs/wre/girlswrxentry.pdf>.

It is highly recommended, but not required, that all events be scored live using TrackWrestling. If the host school does not score the event live using TrackWrestling, then the host school has the responsibility for inputting results for all participating teams within 24 hours after the conclusion of the event.

In the case where an OSAA member school is competing outside of Oregon, it is the responsibility of the member school to input the results into TrackWrestling

Mat Configurations:

Schools are required to comply with NFHS Wrestling Rule(s) 2-2-1, 2-2-2 and 2-1-5 when hosting duals or tournaments. Please review the following rules with all coaches and event personnel prior to the first event you host.

Rule 2-2-1: For dual meets, all team personnel, including coaches, other than actual participating contestants shall be restricted to an area which is at least 10 feet from the edge of the mat and the scorer's table, where facilities permit.

Rule 2-2-2: During tournament competition, a maximum of two team personnel (coaches and/or non-participating contestants) will be permitted on chairs at the edge of the mat. It is permissible to allow coaches on the corner of the mat in a restricted zone. In tournaments where coaches are permitted on the corner of the mat, the restricted zone shall be defined by either a contrasting line marked on the mat with paint or tape or a contrasting colored surface under the chairs. The restricted zone shall be no closer than 5 feet to the edge of the circle. Coaches shall be seated at least 10 feet from the scorer's table, where facilities permit.

Wrestling Mat Rule 2-1

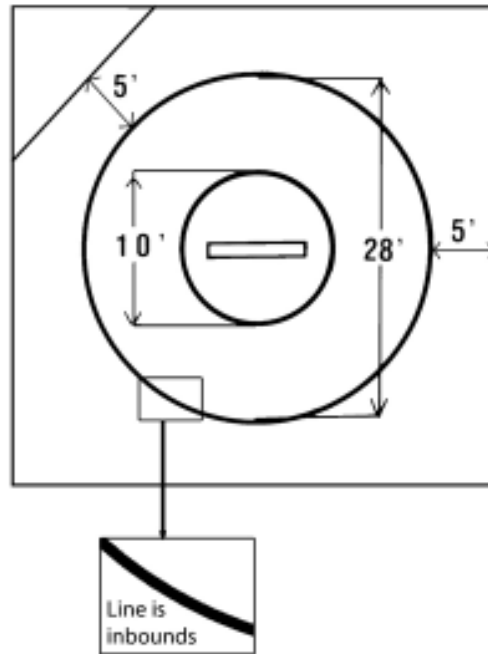

Wrestling Mat Area Rule 2-1-5

MAT AREA

